



# Hobby Link International

SERVING THE WORLD OF MODELERS



Thank you for purchasing our **HLIFX\_002 - Planes Lighting Control Board** from the Hobby Link International Shop! We hope that you will enjoy using this control board for your lighting effects needs. **This board will control flashers for the wing lights, tail lights and fuselage/beacon lights for both civilian and military aircraft, with different lighting modes available via connections that can be jumpered to the ground of your circuit.** We have designed this board to be simple in application, whilst also considering some of the effects you might see on real world aircraft.

Please take the time to carefully, and thoroughly, read and understand these instructions. Any use of this board beyond our recommendations or stated limits, or ignoring any and all warnings is at your own risk. We also take no responsibility if you physically alter or modify the board, or mishandle it in any way. If you have any questions, do not hesitate to contact us using the available information at the end of these instructions.

Included with your kit should be:

- **1 x Control Board (HLIFX\_002)**
- **7 Male Header Pins**

Other things you will or may also need:

- One or two in-line switches. Either of the push-button latching or toggle type.
- Hookup Wire and Heat Shrink Tubing
- Wire Cutters/Strippers
- A Soldering Iron or Soldering Station
- Solder with a Flux or Rosin Core

**SECTION 1:** Let's begin with an overview of the board. On the left is a top down view, the right is bottom up. We have placed connection labels on the underside of the board to save space.

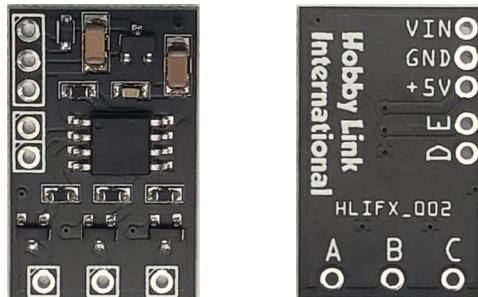

Points **A** thru **E** are the control and lighting pins for the board. **VIN** and **GND** are your connections for power. **The board is tolerant for both 9V and 12V DC**, so you can use either one to power the board. **+5V** is a 5V output pin, **but it is not used for the Planes circuit**, so you can leave it disconnected. You can solder wire directly to these thru-hole connections, use male header pins, or any other method you prefer.

**SECTION 2:** This section will show you how to connect your LEDs to the board.

Several different types of LEDs can be used with this board, including but not limited to: 3mm, 5mm and surface mount LEDs. Below is the standard configuration for a 3mm or 5mm LED (left) and the schematic symbol for an LED (right)

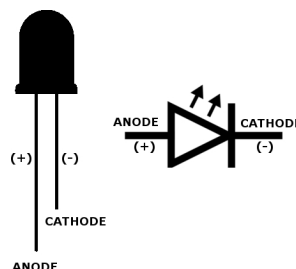

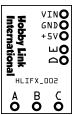

The wiring diagram for a typical circuit, being driven at 9V, is shown below. Study it carefully and become familiar with it. **Your LEDs WILL need to be current limited using dropper resistors**, with recommended values for 9V power shown in the diagram.

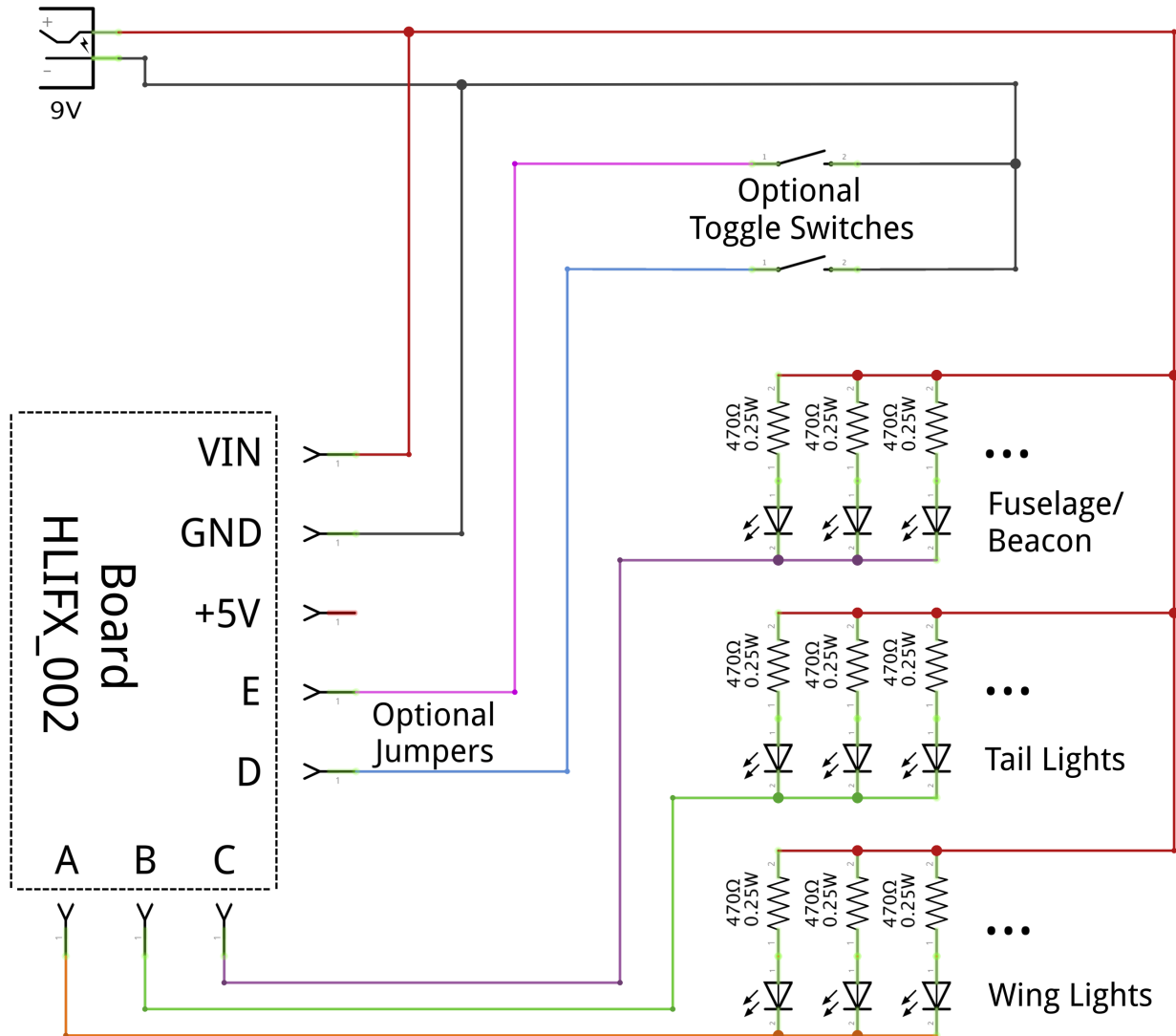

The LEDs will be driven from your 9V-12V power supply, so, if you choose to wire them yourself:

At 9V power, we recommend using at least 470 Ohm, ¼ Watt rated resistors.

At 12V power, we recommend using at least 680 Ohm, ¼ Watt rated resistors.

You can use pre-resistored LEDs, as long as they are rated for AT LEAST the voltage of your DC power supply.

A description of each pin's function and how to wire them to your circuit now follows:

**VIN:** This is the connection for your + voltage supply line. **THE BOARD IS OPTIMIZED TO WORK AT 9V-12V POWER.** We recommend the use of an AC-DC wall adapter/transformer if you are going to be driving more than a handful of LEDs with this board.

**GND:** This is your ground connection, or the negative power connection if you are using a battery or similar source.

**+5V:** This pin has a voltage of +5 volts from the onboard power circuitry. This pin is meant for future designs that may require the need for 5V, but it is not needed for the Planes circuit. **You can ignore this pin and leave it disconnected.**

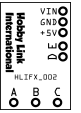

**A:** This point is where you will connect the wing flasher LEDs. These flashers are synced to the tail flashers on **B**. Multiple LEDs in parallel (up to 12) can be connected to this channel as shown above. The primary power line (9V in the diagram) connects to the high side (positive or anode side) of the LED-resistor pairs. The return side (negative or cathode side) of the pairs are tied together to a common return wire that runs back to point **A** of the board.

**NEVER connect VIN OR POWER in ANY way to point A under ANY circumstances or you risk damaging your board!**

**B:** This point is where you will connect the tail flasher LEDs. These flashers are synced to the wing flashers on **A**. Multiple LEDs in parallel (up to 12) can be connected to this channel as shown above. The primary power line (9V in the diagram) connects to the high side (positive or anode side) of the LED-resistor pairs. The return side (negative or cathode side) of the pairs are tied together to a common return wire that runs back to point **B** of the board.

**NEVER connect VIN OR POWER in ANY way to point B under ANY circumstances or you risk damaging your board!**

**C:** This point is where you will connect the flashing fuselage/beacon LEDs. Multiple LEDs in parallel (up to 12) can be connected to this channel as shown above. The primary power line (9V in the diagram) connects to the high side (positive or anode side) of the LED resistor pairs. The return side (negative or cathode side) of the pairs are tied together to a common return wire that runs back to point **C** of the board.

**NEVER connect VIN OR POWER in ANY way to point C under ANY circumstances or you risk damaging your board!**

**D:** This point is where you will connect an optional jumper wire to ground to select different flasher modes for the board. A breakdown of the different modes and which pins to jumper or leave disconnected can be found below. If you need to jumper this point, connect/solder one end of a wire to point **D**, and then run the other end of your wire to the ground of your circuit. You can also install an optional in line switch, so that you can jumper point **D** or disconnect it at will. This switch must be a latching push-button or toggle type. Note that changing this state will NOT register until the board is re-powered.

**NEVER connect VIN OR POWER in ANY way to point D under ANY circumstances or you risk damaging your board!**

**E:** This point is where you will connect an optional jumper wire to ground to select different flasher modes for the board. A breakdown of the different modes and which pins to jumper or leave disconnected can be found below. If you need to jumper this point, connect/solder one end of a wire to point **E**, and then run the other end of your wire to the ground of your circuit. You can also install an optional in line switch, so that you can jumper point **E** or disconnect it at will. This switch must be a latching push-button or toggle type. Note that changing this state will NOT register until the board is re-powered.

**NEVER connect VIN OR POWER in ANY way to point D under ANY circumstances or you risk damaging your board!**

## Aircraft Flasher Mode Selection

Point D	Point E	Mode	Wings (A)	Tail (B)	Beacon (C)
Disconnected	Disconnected	Airbus	Double Flash	Single Flash	Single Flash
Jumper to Ground	Disconnected	Boeing	Single Flash	Single Flash	Single Flash
Disconnected	Jumper to Ground	Military 1	Single Flash	Single Flash	Triple Flash
Jumper to Ground	Jumper to Ground	Military 2	Single Flash	Single Flash	Slow Double Flash

**It is CRITICAL that ALL THE CONNECTIONS TO THE LEDs AND YOUR WIRING ARE INSULATED FROM EACH OTHER AND DO NOT TOUCH, or you could short and potentially damage the circuit!**

For proper, soldered connections on you LED-resistor pairs, you should first solder one of the resistor leads to the ANODE(+) of the LED. Then, solder your hookup wire to the other resistor lead and secure the whole thing with heat shrink tubing. Use your soldering iron, heat gun, lighter or similar heat source to carefully shrink the tubing and insulate the connections. Then solder another piece of hookup wire to the CATHODE (-) of the LED and secure with heat shrink. **SECTION 3** covers some of the aspects of soldering in more detail.

Once all the connections are made, you simply apply power to the circuit and it should immediately begin running. **Be sure to double check that no connections are touching or are shorted before you apply power.** You can use hot glue on the underside of the board to secure it wherever you need to.



**SECTION 3:** Our circuit, as with most circuits, does require some amount of soldering, so we will discuss that briefly here.

First, a good quality soldering iron is a must, preferably a station with temperature control. Soldering temperatures need not be extreme. The author has had his iron set to about 600F (~320C) for a long time without any issues. Use of a “screwdriver” style iron tip is also helpful. It will transfer heat more effectively than a pointed tip that has a much smaller area of contact.

Flux is also critical. Flux cleans away any oxidation and helps the solder flow over the areas it needs to go, so make sure you are using solder that has a flux core. Keep in mind that lead free solders require higher temperatures to solder properly. 60/40 Tin-Lead Rosin core solder is quite common and effective. A tub of Rosin flux is also useful for applying flux directly to what needs soldering.

It is important to coat your iron tip with a thin layer of solder before getting to work. Sometimes called “tinning” or “pre-tinning.” This helps heat transfer more efficiently and reduce oxidation due to high temperatures. When soldering with wires or resistor/LED leads, it is also a good idea to pre-tin them as well before actually soldering them together. Our board connections should already be pre-tinned.

For joining pre-tinned wires, first take both ends you wish to solder and either bring them together or twist them together. Put a small dab of solder onto your tinned iron tip and make contact with the wires on the underside of the joint. Let the wires heat for a few seconds and then touch your solder wire to the joint. The solder should melt and wick into and around the joint. Remove the solder wire and then the iron and wait for the joint to cool and the solder to solidify. The process is very similar to soldering wire to LED and resistor leads. A set of helping hands to hold the wires and leads in place can also be quite useful.

For soldering wire to a circuit board, first take your hookup wire and insert it into the PCB’s thru-hole point from the top side down. This way, you can solder on the underside of the board and avoid accidentally damaging components on the top side with your iron tip. Make sure your iron tip is pre-tinned and apply a small dab of solder to it. Bring the tip into contact with both the hookup wire and solder pad of the board, waiting a couple of seconds to heat them up. Then touch the solder wire to the joint, trying to avoid touching the iron tip. The solder should wick and flow around the wire and the pad. Remove the solder wire and then the iron and let the joint cool and solidify.

We have published a short demo video of this circuit on the HLI YouTube channel. You can grab the link to it the QR code below. The product page on the HLI Shop should also have a link to the demo video and these instructions, if you misplace them. There are also plenty of YouTube videos and online articles on how to solder wires and leads together, as well as soldering to circuit boards. You can also purchase soldering practice kits from Amazon and eBay to try out before committing to our board.

We thank you once again for purchasing the Planes Control Board and hope it serves you well! If you have any questions, please feel free to [contact us!](#)

Relevant HLI links and contact info:



Be sure to check back at the Hobby Link International Shop often for other lighting kits and control boards that we will be producing. And if you haven’t already, stop by the main Hobby Link International website, and especially our community forums. There are lots of great, friendly people over there with subjects to cover almost every aspect of scale modeling!

Cheers,  
Spencer Wolfe – Design and Testing  
Tom Conklin – Design and Assembly  
Kenny Conklin – Resident “Stress Test” ;) and Sales  
Paul Tosney – Procurement and Sales

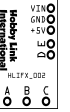

## Warranty Disclaimer (Light & Sound Kits)

### Warranty

Thank you for your interest in the products and services of Hobby Link International.

This Limited Warranty applies to physical goods in our light & sound kits purchased from Hobby Link International (the "Physical Goods").

### What does this limited warranty cover?

This Limited Warranty covers any defects in material or workmanship under normal use during the Warranty Period.

During the Warranty Period, Hobby Link International will repair or replace, at no charge, products or parts of a product that proves defective because of improper material or workmanship, under normal use and maintenance.

### What will we do to correct problems?

Hobby Link International will either repair or replace the Product at no charge, using new or refurbished replacement parts.

### How long does the coverage last?

The Warranty Period for Physical Goods purchased from Hobby Link International is 10 years from the date of purchase. A replacement Physical Good or part assumes the remaining warranty of the original Physical Good.

### What does this limited warranty not cover?

This Limited Warranty does not cover any problem that is caused by:

- conditions, malfunctions or damage not resulting from defects in material or workmanship

### What do you have to do?

To obtain warranty service, you must first contact us via [info@hobbylinkinternational.com](mailto:info@hobbylinkinternational.com) to determine the problem and the most appropriate solution for you.