

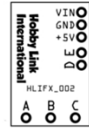

Hobby Link International

SERVING THE WORLD OF MODELERS



Thank you for purchasing our **HLIFX_002 - Keaton Batwing Lighting Control Board** from the Hobby Link International Shop! We hope that you will enjoy using this control board for your lighting effects needs. **This board will produce a double flashing strobe effect, two pseudo-random cockpit blinkers, as well as a machine gun bursting effect via a button press.** We have designed this board to be pretty straightforward in application and consider some of the effects you might see on a billionaire's personal crime-fighting aircraft.

Please take the time to carefully and thoroughly read and understand these instructions. Any use of this board beyond our recommendations or stated limits or ignoring any warnings is at your own risk. We also take no responsibility if you physically alter or modify the board or mishandle it in any way. If you have any questions, do not hesitate to contact us using the available information at the end of these instructions.

Included with your kit should be:

- **1 x Control Board (HLIFX_002)**
- **7 Male Header Pins**

Other things you will or may also need:

- **One momentary pushbutton switch that is normally open (push to close)**
- Hookup Wire and Heat Shrink Tubing
- Wire Cutters/Strippers
- A Soldering Iron or Soldering Station
- Solder with a Flux or Rosin Core

SECTION 1

Let's begin with an overview of the board. On the left is a top-down view, the right is bottom-up. We have placed connection labels on the underside of the board to save space.



Points **A** thru **E** are the control and lighting pins for the board. **VIN** and **GND** are your connections for power. **The board is tolerant for both 9V and 12V DC**, so that you can use either one to power the board. **+5V** is a 5V output pin, **but it is not used for the Batwing circuit**, so you can leave it disconnected. You can solder a wire directly to these thru-hole connections, use male header pins, or any other method you prefer.

SECTION 2

This section will show you how to connect your LEDs to the board.

Several different types of LEDs can be used with this board, including but not limited to 3mm, 5mm and surface-mount LEDs. Below is the standard configuration for a 3mm or 5mm LED (left) and the schematic symbol for an LED (right.)

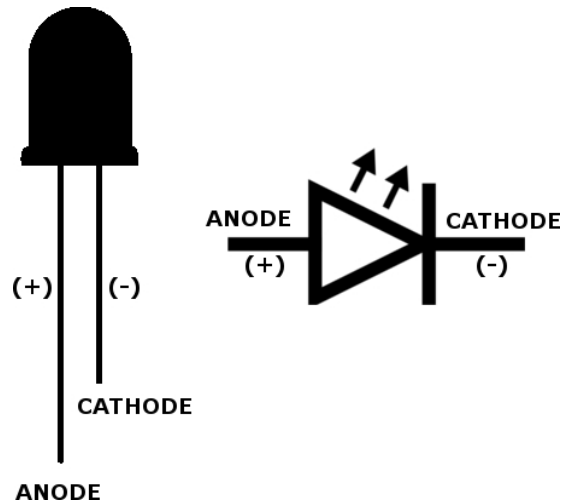

The wiring diagram for a typical circuit being driven at 9V is shown below. Study it carefully and become familiar with it. **Your LEDs WILL need to be current limited using dropper resistors**, with recommended values for 9V power shown in the diagram.

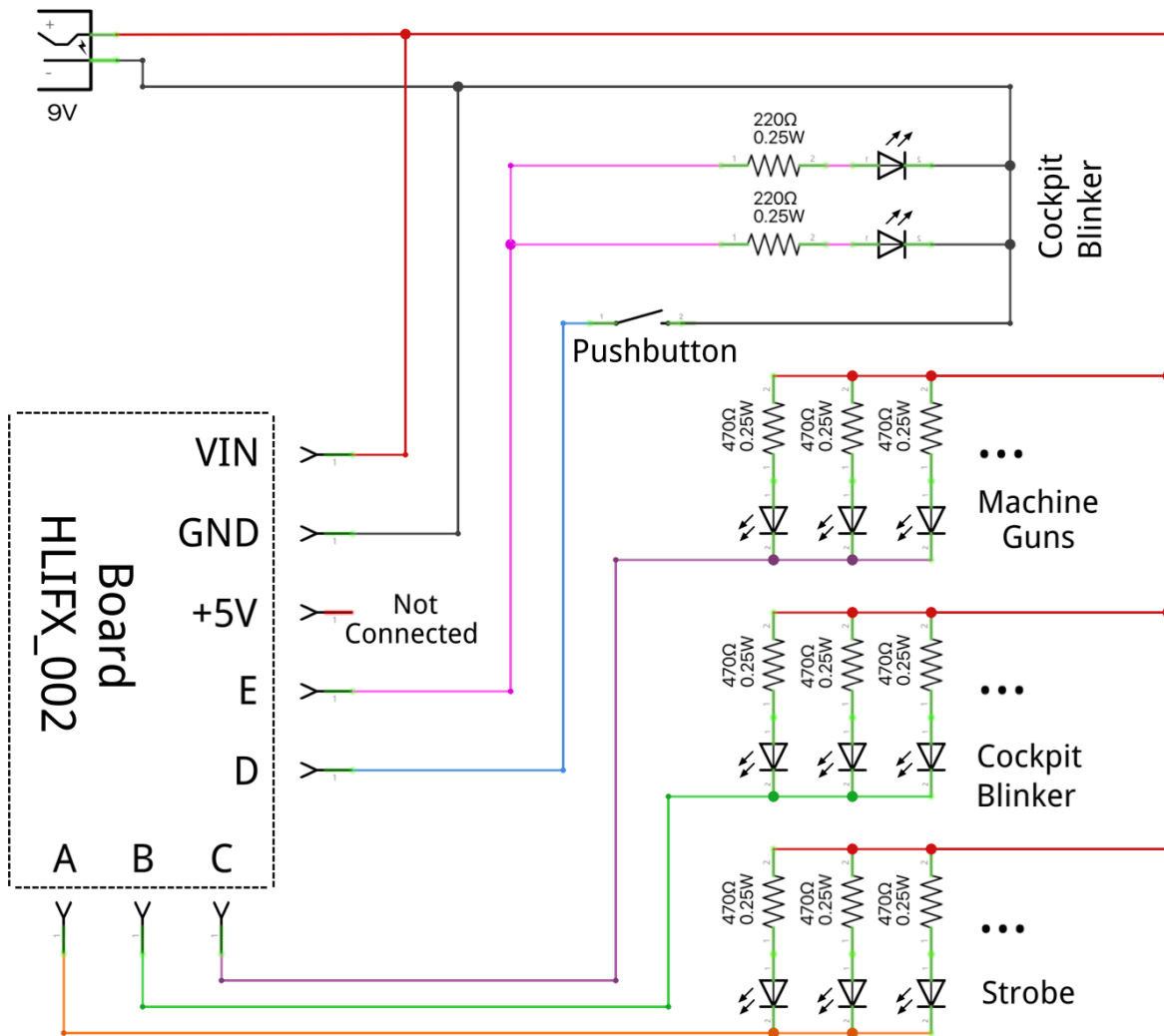

The strobing LEDs, machine gun LEDs and one set of cockpit LEDs will be driven from your 9V-12V power supply, so, if you choose to wire them yourself:

At 9V power, we recommend using at least 470 Ohm, 1/4 Watt rated resistors. At 12V power, we recommend using at least 680 Ohm, 1/4 Watt rated resistors. You can use pre-resistored LEDs, as long as they are rated for AT LEAST the voltage of your DC power supply.

A second, optional set of cockpit blinkers are powered directly from the board and will require at least 220 Ohm, 1/4 Watt rated resistors to function correctly. You can use pre-resistored LEDs, as long as they are rated for AT LEAST 5V power.

A description of each pin's function and how to wire your LED-Resistor pairs to them now follows:

VIN:

This is the connection for your + voltage supply line. **THE BOARD IS OPTIMIZED TO WORK AT 9V-12V POWER.** We recommend using an AC-DC wall adapter/transformer if you are going to be driving more than a handful of LEDs with this board.

GND:

This is your ground connection or the negative power connection if you use a battery or similar source.

+5V:

This pin has a voltage of +5 volts from the onboard power circuitry. This pin is meant for future designs that may require the need for 5V, but it is not needed for the Batwing circuit. **You can ignore this pin and leave it disconnected.**

A:

NEVER connect VIN OR POWER in ANY way to point A under ANY circumstances, or you risk damaging your board!

This point is where you will connect the dual flashing, anti-collision strobe circuit. As shown above, multiple LEDs in parallel (up to 15) can be connected to this channel. The primary power line (9V in the diagram) connects to the high side (positive or anode side) of the LED-resistor pairs. The return side (negative or cathode side) of the pairs are tied together to a common return wire that runs back to point **A** of the board. While the Batwing in the 1989 film did not have external blinkers, we provide this effect as an option to those who wish to have anti-collision lights. You could also use this effect in the cockpit as a kind of flasher warning if you want.

B:

NEVER connect VIN OR POWER in ANY way to point B under ANY circumstances, or you risk damaging your board!

This point is where you will connect the pseudo-random cockpit blinking circuit. As shown above, multiple LEDs in parallel (up to 15) can be connected to this channel. The primary power line (9V in the diagram) connects to the high side (positive or anode side) of the LED-resistor pairs. The return side (negative or cathode side) of the pairs are tied together to a common return wire that runs back to point **B** of the board. We provide this effect to give a random blinking option for the cockpit for those who wish to have one.

C:

NEVER connect VIN OR POWER in ANY way to point C under ANY circumstances, or you risk damaging your board!

This point is where you will connect the machine gun bursting effect circuit. The effect will fire random bursts for about 8 seconds, with individual light pulses for each burst. The effect is controlled through the momentary pushbutton connected to point **D**. Multiple LEDs in parallel (up to 15) can be connected to this channel, as shown above, to allow for lighting the wing guns, mandible cannons and optional pop out mini-gun. The primary power line (9V in the diagram) connects to the high side (positive or anode side) of the LED-resistor pairs. The return side (negative or cathode side) of the pairs are tied together to a common return wire that runs back to point **C** of the board.

D:

NEVER connect VIN OR POWER in ANY way to point D under ANY circumstances, or you risk damaging your board!

This point is where you will connect a momentary pushbutton switch to control the machine gun bursting effect for the LEDs connected to **C**. You will connect, or solder, a wire to point **D** and run that to one side of your momentary switch. Then, you will run a wire from the other side of your switch to the main ground wire of the circuit that comes from your power supply. This switch needs to be a momentary pushbutton switch that is normally open and is pushed to close to make electrical contact.

E:

NEVER connect VIN OR POWER in ANY way to point E under ANY circumstances, or you risk damaging your board!

This point is where you will connect another optional pseudo-random cockpit blinking circuit. Up to **TWO** LEDs in parallel can be connected to this point. You will run wiring from point **E** of the board to the high side (positive or anode side) of the LED-resistor pairs. The return side (negative or cathode side) of the pairs are tied together and connect to the main ground wire of the circuit that comes from your power supply. This pin allows for an optional, second random blinking effect for the cockpit.

It is CRITICAL that ALL THE CONNECTIONS TO THE LEDs AND YOUR WIRING ARE INSULATED FROM EACH OTHER AND DO NOT TOUCH, or you could short and potentially damage the circuit!

For proper, soldered connections on your LED-resistor pairs, you should first solder one of the resistor leads to the ANODE(+) of the LED. Then, solder your hookup wire to the other resistor lead and secure the whole thing with heat shrink tubing. Use your soldering iron, heat gun, lighter, or similar heat source to shrink the tubing and insulate the connections carefully. Then solder another piece of hookup wire to the CATHODE (-) of the LED and secure with heat shrink. **SECTION 3** covers some of the aspects of soldering in more detail.

Once all the connections are made, you apply power to the circuit, and it should immediately begin running. **Be sure to double-check that no connections are touching or are shorted before you apply power.** You can use hot glue on the underside of the board to secure it wherever you need to.

SECTION 3

Our circuit, as with most circuits, does require some amount of soldering, so we will discuss that briefly here.

First, a good quality soldering iron is a must, preferably a station with temperature control. Soldering temperatures need not be extreme. The author has had his iron set to about 600F (~320C) for a long time without any issues. The use of a "screwdriver" style iron tip is also helpful. It will transfer heat more effectively than a pointed tip that has a much smaller area of contact.

Flux is also critical. Flux cleans away any oxidation and helps the solder flow over the areas it needs to go, so make sure you are using a solder that has a flux core. Keep in mind that lead-free solders require higher temperatures to solder correctly. 60/40 Tin-Lead Rosin core solder is quite common and effective. A tub of Rosin flux is also helpful for applying flux directly to what needs soldering.

It is important to coat your iron tip with a thin layer of solder before getting to work. Sometimes called "tinning" or "pre-tinning." Pre-tinning helps heat transfer more efficiently and reduces oxidation due to high temperatures. When soldering with wires or resistor/LED leads, it is also good to pre-tin them before soldering them together. Our board connections should already be pre-tinned.

For joining pre-tinned wires, take both ends you wish to solder and either bring them together or twist them together. Put a small dab of solder onto your tinned iron tip and make contact with the wires on the underside of the joint. Let the wires heat for a few seconds, and then touch your solder wire to the joint. The solder should melt and wick into and around the joint. Remove the solder wire and then the iron and wait for the joint to cool and the solder to solidify. The process is very similar to soldering wire to LED and resistor leads. A set of helping hands to hold the wires and leads in place can also be quite helpful.

For soldering wire to a circuit board, first, take your hookup wire and insert it into the PCB's thru-hole point from the top side down. This way, you can solder on the underside of the board and avoid accidentally damaging components on the top side with your iron tip. Make sure your iron tip is pre-tinned and apply a small dab of solder to it. Bring the tip into contact with both the hookup wire and solder pad of the board, waiting a couple of seconds to heat them. Then touch the solder wire to the joint, trying to avoid touching the iron tip. The solder should wick and flow around the wire and the pad. Remove the solder wire and then the iron and let the joint cool and solidify.

We have published a short demo video of this circuit on the HLI YouTube channel. You can grab the link to it the QR code below. The product page on the HLI Shop should also have a link to the demo video and these instructions if you misplace them.

There are also plenty of YouTube videos and online articles on how to solder wires and leads together and soldering to circuit boards. You can also purchase soldering practice kits from Amazon and eBay to try out before committing to our board.

Thank you again for purchasing the Keaton Batwing Lighting Control Board, and we hope it serves you well! If you have any questions, please feel free to [contact us!](#)

Relevant HLI links and contact info:



Be sure to check back at the Hobby Link International Shop often for other lighting kits and control boards that we will be producing. And if you haven't already, stop by the main Hobby Link International website, especially our community forums. There are many great, friendly people over there with subjects to cover almost every aspect of scale modeling!

Cheers,

Spencer Wolfe – Design and Testing

Tom Conklin – Design and Assembly

Kenny Conklin – Resident "Stress Test" ;) and Sales

Paul Tosney – Procurement and Sales

Warranty Disclaimer (Light & Sound Kits)

We appreciate your interest in the products and services of Hobby Link International.

This Limited Warranty applies to physical goods in our light & sound kits purchased from Hobby Link International (the "Physical Goods").

What does this limited warranty cover?

This Limited Warranty covers any defects in material or workmanship under normal use during the Warranty Period.

During the Warranty Period, Hobby Link International will repair or replace, at no charge, products or parts of a product that proves defective because of improper material or workmanship under normal use and maintenance.

What will we do to correct problems?

Hobby Link International will either repair or replace the Product at no charge, using new or refurbished replacement parts.

How long does the coverage last?

The Warranty Period for Physical Goods purchased from Hobby Link International is ten years from the date of purchase. A replacement Physical Good or part assumes the remaining warranty of the original Physical Good.

What does this limited warranty not cover?

This Limited Warranty does not cover any problem that is caused by:

- conditions, malfunctions, or damage not resulting from defects in material or workmanship

What do you have to do?

To obtain warranty service, you must first contact us via info@hobbylinkinternational.com to determine the problem and the most appropriate solution for you.